



Vincotech

UNRIVALLED IN MOTION CONTROL

Deepest integration, highest
performance

EMPOWERING YOUR IDEAS

EMBEDDED DESIGNS DRIVE TOMORROW'S SOLUTIONS

Higher performance

Embedded drive solutions for motion control **simplify integration, enhance performance and speed up time-to-market**. Vincotech's power module lineup represents the best fit for highly reliable, low-cost motor controls that deliver **higher performance in a smaller footprint**.

Embedded drive solutions for Industrial motion control

Higher integration and more complex sub-systems are some of the current trends in the industrial market. Embedded drive systems:

- / integrate drives and electric motors to reduce the space occupancy thanks to their **compact and hermetically sealed design**
- / can be optimized to increase both the **reliability and performance**
- / **reduce the overall system's size, cost, and time-to-market** by considerably increasing the level of integration

Discrete drives are standard solutions designed to control a wide range of motion applications. However, they contain filters, connectors, and cables to be assembled and tested for UL and /or CE certifications. This increases the assembly time and the overall system cost.

Product portfolio

Space is tight in embedded drive systems, and their compact, hermetical design makes it difficult to dissipate the heat generated by so many electronic components.

Vincotech's power module portfolio for embedded drives features **600 V and 1200 V** intelligent power modules (**IPMs**) as well as power integrated modules integrating PFC circuit (**PIM+PFC**). All of a motor drive's functional blocks, apart from the input filter, DC capacitor and microcontroller can be integrated.

- / Highest level of integration of any power module available on the market
- / Best solution for such space-constrained mechanical environments
- / Lower overall system's size, cost, and time-to-market

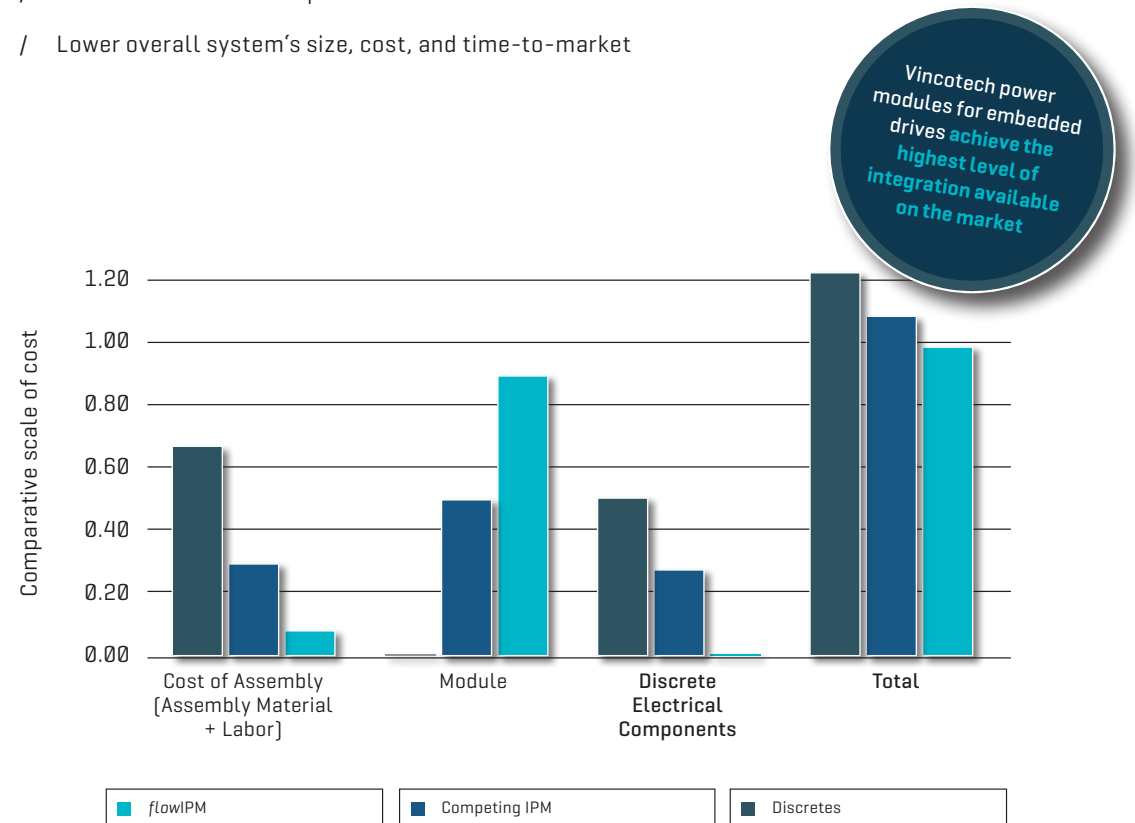

Figure 1: Cost analysis - flowIPM vs. discrete and competing IPM

Protection circuitry is tuned to match the power device's capability, and factory-tested to improve the system's reliability. **Space is saved with highly integrated components and bare power chips** to achieve a much smaller footprint than that of discrete designs.

Think Integrated

Vincotech's product portfolio provides the functional integration and power density that engineers need to **design embedded drive systems**.

The **outstanding level of integration** achieved by Vincotech's intelligent power modules enables system engineers to come up with **more compact designs** and to take advantage of a proven combination of power components and gate drive circuits, which is the most critical elements in the inverter's design.

This mitigates the risk associated with circuit design, speeds up development, and dramatically reduces time to market.

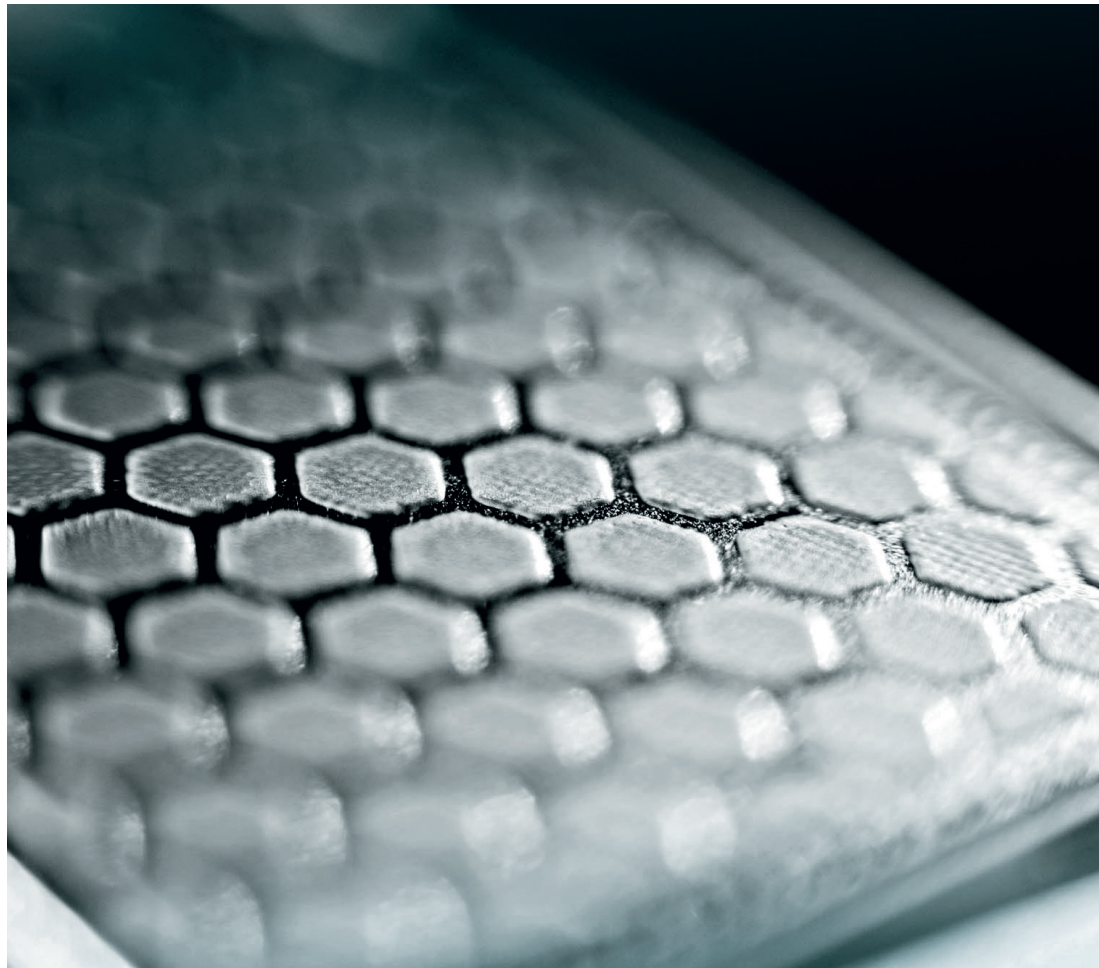

Figure 2: Phase-change material

Motor drive assembly is streamlined and simplified with fewer external components and smart isolation techniques.

- / **The ceramic sheet** used in thick-film technology improves the module's thermal performance by providing **the best possible direct cooling** for power components
- / Very compact housings equipped with **Press-fit pins** [see Figure 2]
- / **Press-fit technology** reduces PCB assembly time and effort considerably by eliminating the need for soldering. This cuts process time and costs, and boosts production output



Figure 3: Press-fit pins for solder-less mounting

The module's **creepage and clearance** distances fulfill the applicable industrial standards. There are no special requirements regarding the shape of the heat sink.

The thermal interconnection between the power module and the heat sink is vastly improved by pre-applying phase-change material [see Figure 3]. Vincotech's in-house screen-printing process deposits the material with great precision, achieving the proper thickness. The material can be optimized for maximum heat transfer capability.



PRODUCT PORTFOLIO

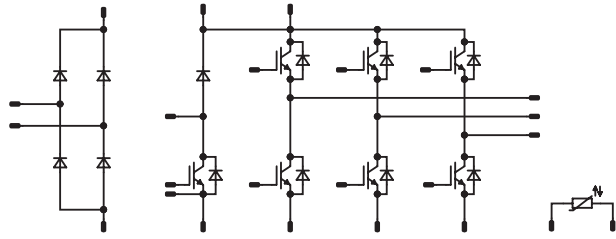

flowPIM 0B + PFC	Voltage in V	Current in A	Chip Technology	Housing family	Height in mm
10-0B06PPA004RC-L022A09	600	4	IGBT RC	flow 0B	17
10-0B06PPA006RC-L023A09	600	6	IGBT RC	flow 0B	17
10-0B06PPA010RC-L025A09	600	10	IGBT RC	flow 0B	17
10-0B06PPA010RC01-L025A19	600	10	IGBT RC	flow 0B	17
10-0B06PPA010RC02-L025A89	600	10	IGBT RC	flow 0B	17

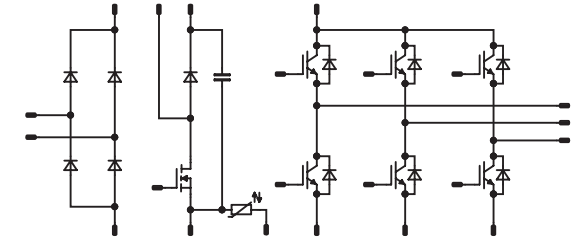

flow90PIM 1 + PFC	Voltage in V	Current in A	Chip Technology	Housing family	Height in mm
10-R106PPA020SB01-M934A	600	20	IGBT 3LL	flow 90	10

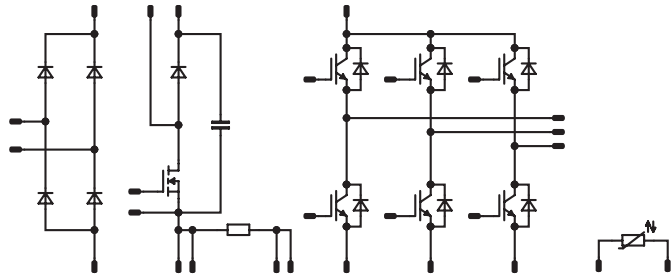

flowPIM 0 + PFC	Voltage in V	Current in A	Chip Technology	Housing family	Height in mm
10-F006PPA010M701-LT23B79	650	10	IGBT M7	flow 0	17
10-F006PPA010SB-M683B	600	10	COOLMOS	flow 0	17
10-F006PPA010SB03-M683B50	600	10	IGBT3	flow 0	17
10-F006PPA015SB04-M684B09	600	15	IGBT3 LL	flow 0	17
10-F006PPA020SB01-M685B10	600	20	IGBT3 LL	flow 0	17
10-F006PPA020SB02-M685B30	600	20	IGBT F5	flow 0	17
10-F006PPA020SB03-M685B09	600	20	IGBT3 LL	flow 0	17
10-FZ06PPA030SJ-LS54E08	600	30	IGBT FAST	flow 0	17
10-P006PPA010SB-M683BY	600	10	CoolMOS	flow 0	17
10-P006PPA010SB04-M683B30Y	600	10	IGBT F5	flow 0	17
10-P006PPA015SB03-M684B30Y	600	15	IGBT F5	flow 0	17
10-P006PPA020SB01-M685B10Y	600	20	IGBT3	flow 0	17
10-P006PPA020SB02-M685B30Y	600	20	IGBT F5	flow 0	17
10-P006PPA020SB03-M685B09Y	600	20	IGBT3 LL	flow 0	17

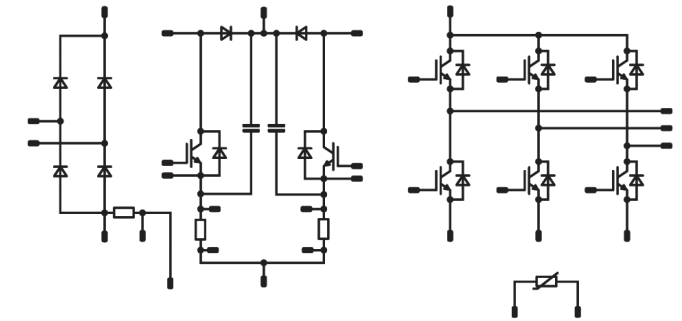

flowPIM 1 + PFC	Voltage in V	Current in A	Chip Technology	Housing family	Height in mm
10-FE06PPA020SJ01-LK23B58Z	650	20	IGBT FAST	flow 1	12
10-FE06PPA020SJ06-LV81B03Z	600	20	IGBT FAST	flow 1	12
10-P106PPA050SJ-PD54B09Y	600	50	IGBT FAST	flow 1	12
10-PG06PPA020SJ-LJ01B08T	600	20	IGBT FAST	flow 1	12
10-PG06PPA030SJ-LJ02B08T	600	30	IGBT FAST	flow 1	12
10-PG06PPA030SJ01-LH52E08T	600	30	IGBT FAST	flow 1	12
10-PG06PPA030SJ02-LH92E08T	600	30	IGBT FAST	flow 1	12
10-PG06PPA030SJ04-LJ02B03T	600	30	IGBT FAST	flow 1	12
10-PG06PPA050SJ-LJ04B08T	600	50	IGBT FAST	flow 1	12
10-PG06PPA050SJ01-LH54E08T	600	50	IGBT FAST	flow 1	12
10-PG06PPA050SJ02-LH94E08T	600	50	IGBT FAST	flow 1	12

PRODUCT PORTFOLIO

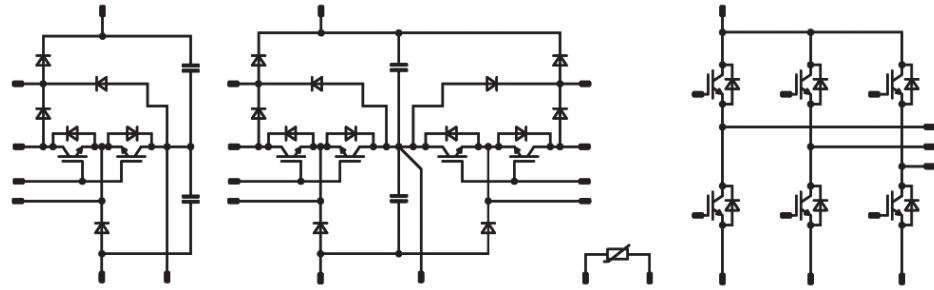

flowPIM1 + 3xPFC	Voltage in V	Current in A	Chip Technology	Housing family	Height in mm
10-FE12APA015SH01-PB18E08Z	1200	15	IGBT F5	flow 1	12
10-PG12APA015SH01-PB18E08T	1200	15	IGBT F5	flow 1	12
B0-SL12PPA040SH-PC88L41Z	1200	40	IGBT4 HS	flow S3	12

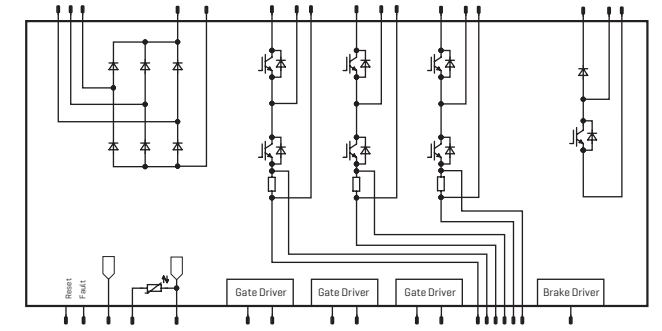

flowIPM 1C (CIB)	Voltage in V	Current in A	Chip Technology	Housing family	Height in mm
20-1C12IBA015SH-LB18A08	1200	15	IGBT4	flow 1C	12

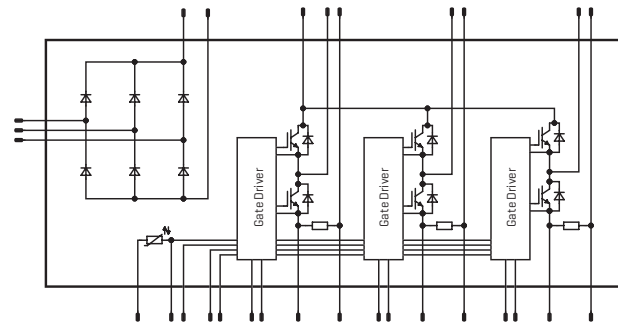

flowIPM 1B (CI)	Voltage in V	Current in A	Chip Technology	Housing family	Height in mm
20-1B12IPA008SC-L239C09	1200	8	IGBT4	flow 1B	17
20-1B12IPA015SC-L579F09	1200	15	IGBT4	flow 1B	17
20-FB12IPA008SC-L239C08Y	1200	8	IGBT4	flow 1B	12

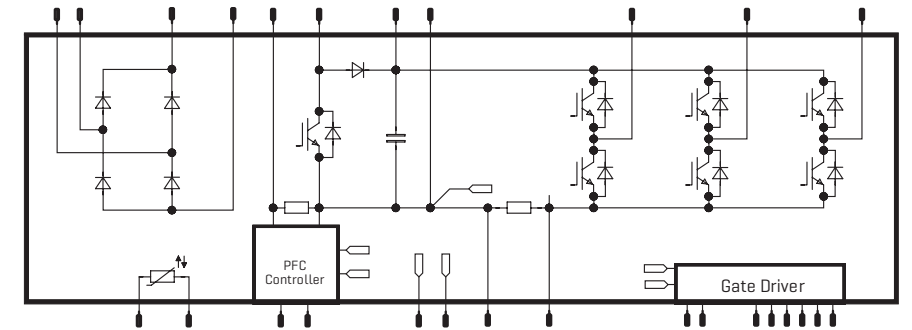

flowIPM 1B (CI)	Voltage in V	Current in A	Chip Technology	Housing family	Height in mm
20-1B06IPB004RC-P952A40	600	4	IGBT RC	flow 1B	17
20-1B06IPB004RC01-P952A45	600	4	IGBT RC	flow 1B	17
20-1B06IPB010RC-P955A40	600	10	IGBT RC	flow 1B	17
20-1B06IPB010RC01-P955A45	600	10	IGBT RC	flow 1B	17
20-1B06IPB010RC03-P955A65	600	10	IGBT RC	flow 1B	17
20-1B06IPB010RC02-L815A49	600	10	IGBT RC	flow 1B	17



Vincotech GmbH

Biberger Strasse 93 / 82008 Unterhaching / Germany
T +49 89 878 067-0 / info@vincotech.com

www.vincotech.com